



# MODEL TSM-1100

## PORTABLE TUBE SQUARING MACHINE

### OPERATING INSTRUCTIONS



**ELITE INDUSTRIAL SALES**

# TSM-1100 PORTABLE TUBE SQUARING MACHINE

## TABLE OF CONTENTS

|    |                              |    |
|----|------------------------------|----|
| 1. | INTRODUCTION .....           | 3  |
| 2. | SAFETY PRECAUTIONS .....     | 4  |
| 3. | DESCRIPTION .....            | 6  |
| 4. | SET-UP AND OPERATION .....   | 7  |
| 5. | OVERVIEW OF OPERATIONS ..... | 11 |
| 6. | MAINTENANCE .....            | 13 |
| 7. | WARRANTY .....               | 14 |
| 8. | MACHINE EXPLODED VIEWS ..... | 16 |

# TSM-1100 PORTABLE TUBE SQUARING MACHINE

## 1. INTRODUCTION

The information in this manual is up to date at the time of printing. Elite Industrial Sales is committed to continued product improvement; the machine you receive may be slightly different than the one described herein.

### Warning:

Moving machine parts can seriously injure untrained operators. Understand all instructions before operating this machine. This manual describes how to use your Model TSM-1100 Portable Tube Squaring Machine. This machine tool is designed for facing tubing and elbows from 1/8" to 1" diameter. For maximum safety and performance, read the entire instruction manual before operating this machine.

### Applications:

This model Tube Squaring Machine can be used in a wide variety of applications but is specifically designed for facing tubing. The modular design and versatile setup allow you to be creative in solving difficult machine problems. However, it is very important to follow the operating manual and maintain integrity of the machine. Do not modify it in any unspecific manner.

### When you receive it:

Inspect the machine for shipping damage. Be sure you received the parts listed on the invoice. Contact Elite Industrial Sales immediately if there are any errors or questions regarding this machine.

# TSM-1100 PORTABLE TUBE SQUARING MACHINE

## 2. SAFETY PRECAUTIONS

The following is a list of general safety guidelines to be considered when operating this tool. Standard safe machining practices should always be followed when operating Elite Industrial Sales Machines.

Before operating this machine, read the entire Operating Instructions. Inspect machine, cord and accessories for any damage.

Wear safety glasses, ear plugs, and safety shoes while operating the machine. Keep your equipment clean and in good condition for maximum protection. Follow company and OSHA safety rules when operating equipment.

The motor should always be disconnected from the drive battery whenever servicing the machine or changing cutting inserts, collets, or other components.

### SAFETY INFORMATION

**WARNING!**

**MOVING PARTS.** Keep hands, loose clothing, and hair away from rotating or moving parts. Remove the drive battery from the machine and unplug all equipment prior to adjusting or servicing.

**WARNING!**

**ELECTRICAL SHOCK.** Possible shock if not handled properly.

**WARNING!**

**KEEP DRY.** Keep all equipment and components away from any water source.

# **TSM-1100 PORTABLE TUBE SQUARING MACHINE**

## **WARNING!**

### **EYE PROTECTION.**

Eye protection must be worn while operating or working near facing equipment.

## **WARNING!**

### **EAR PROTECTION.**

Ear protection should be worn while operating or working near loud equipment.

# **TSM-1100 PORTABLE TUBE SQUARING MACHINE**

## **3. DESCRIPTION**

The TSM-1100 Portable Tube Squaring Machine is designed for facing tubing 1/8" to 1" (metric 3.175 mm to 25.4 mm) diameter. This machine is small, ultra-portable, weighted only around 5.8 lbs or 2.6 kg (including high capacity battery).

The collets are made of aluminum alloy plus hard anodize, and are designed so the integrity of electro-polished tubing is not affected by their use. Our tool bits are designed to work in the following materials: stainless steel, Inconel, Hastelloy, carbon steels, aluminum, and a variety of other alloys.

The standard TSM-1100 package includes:

- Tube Squaring Machine assembled with electric drive unit
- Custom carrying case
- Two standard facing tool bits
- Tool kit
- Battery charger and 1 battery
- Operating manual

Specifications:

- Weight (with motor and battery): 5.8 lbs. (2.6 kg)
- Overall length: 10.5 inches (266.7 mm)
- Overall height: 10.5 inches (266.7 mm)
- Motor: Metabo LTX (may be other brands or models w/o a notice)
- Battery charger:
  - 120VAC; 60 Hz-US style
  - 220VAC; 50 Hz-CE Compliant
- Optional: 90-degree Right Angle Drive.

# TSM-1100 PORTABLE TUBE SQUARING MACHINE

## 4. SET-UP AND OPERATION

### SETUP OF COLLETS

- 1) The collet consists of two parts, the Upper Collet and Lower Collet, and they are designed to use in a pair. To get the best performance, clean the surfaces on the Collet and Collet Seat Areas before installation.
- 2) Unscrew the Lower Collet Cramp Screw and remove the old Collet from machine. And select correct collets for your tubing; insert them into the collet seat from the front; and tighten Lower Collet Cramp Screw.
- 3) Turn the Lock Handle slightly on both direction and see if the Upper Collet moves up and down smoothly.

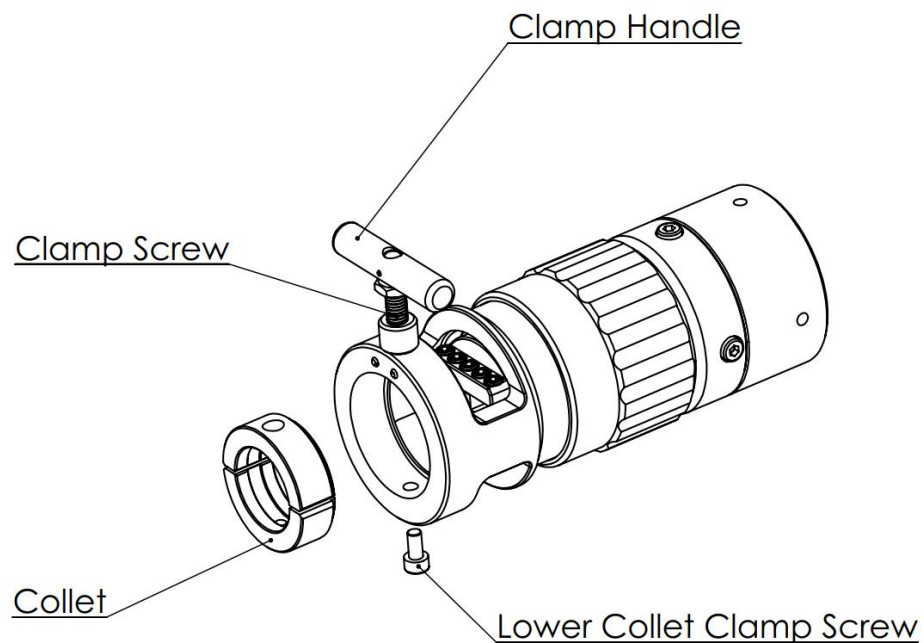

Setup of Collets

# TSM-1100 PORTABLE TUBE SQUARING MACHINE

## 4) List of Standard Collet Part #:

| Part #   | Size        |
|----------|-------------|
| TSM-1080 | 1/8" Tubing |
| TSM-1081 | 1/4" Tubing |
| TSM-1082 | 3/8" Tubing |
| TSM-1083 | 1/2" Tubing |
| TSM-1084 | 5/8" Tubing |
| TSM-1085 | 3/4" Tubing |
| TSM-1086 | 7/8" Tubing |
| TSM-1087 | 1" Tubing   |
|          |             |
|          |             |
|          |             |
|          |             |
|          |             |

## TOOL BIT INSTALLATION

Select the right tool bit for your application. Note that using the wrong type of tool bit or using dull bits may result in poor performance.

To change Tool Bits:

- 1) Remove the battery from the electric motor before installing the tool bits.

# TSM-1100 PORTABLE TUBE SQUARING MACHINE

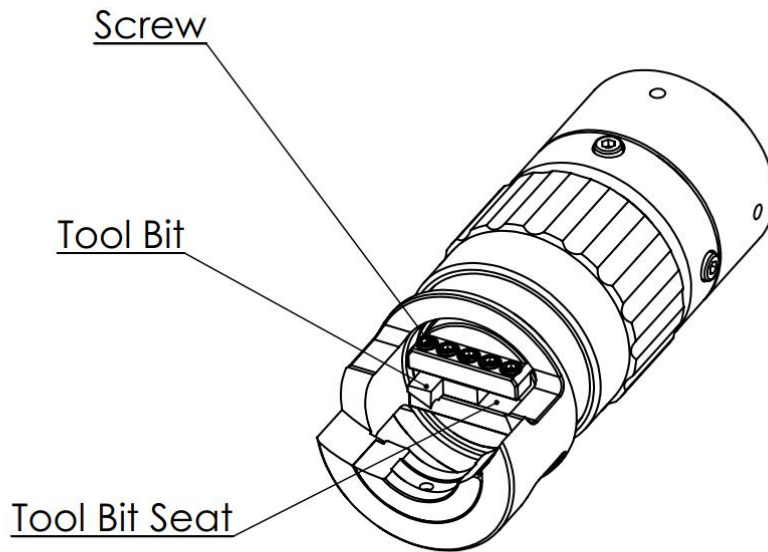

## Tool Bit Installation

- 2) Unscrew the Screws and remove the old tool bit from Tool Bit Seat.
- 3) Clean the tool bit seat slot and set the tool bit at proper location on the seat slot.
- 4) Ensure Tool Bit is insert correctly: set-screw should face back of the tool bit. Cutting edge will face away from set-screw.
- 5) Tighten the screws.
- 6) List of Tool Bit Part # for TSM-1100:

| PART #     | Description                           |
|------------|---------------------------------------|
| TB-1515-LC | Laser Coated Tool Bit for SS Material |

# **TSM-1100 PORTABLE TUBE SQUARING MACHINE**

## **NOTE**

**Slower speeds produce minimum burrs when working with  
Electropolished Stainless Tubing.**

## **CAUTION**

**Running the drill too fast will work harden the Stainless Steel  
Tubing and quickly damage the tool bits**

**For Best Performance, motor speed should be running at a slow  
speed that ensure the motor will not stop during cutting.**

**Slower is better for longer lasting tool bit life**

# TSM-1100 PORTABLE TUBE SQUARING MACHINE

## 5. OVERVIEW OF OPERATIONS

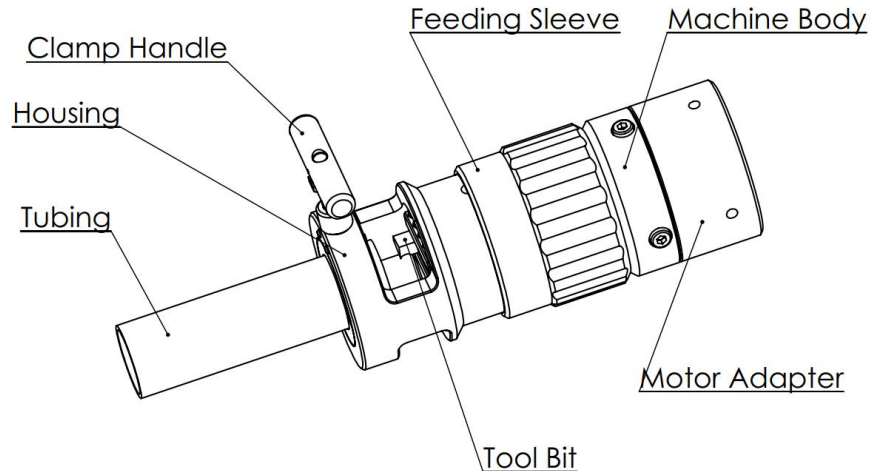

Part & Component Overview

- 1) **Remove Battery** from the battery socket of the electric motor before operation setup.
- 2) Install collets per the section “Setup of Collets”.
- 3) Install tool bit based on the section “Tool Bit Installation”.
- 4) Adjust the cutting tool (tool bit) initial position by turning the Feeding Sleeve. Please refer to the image.

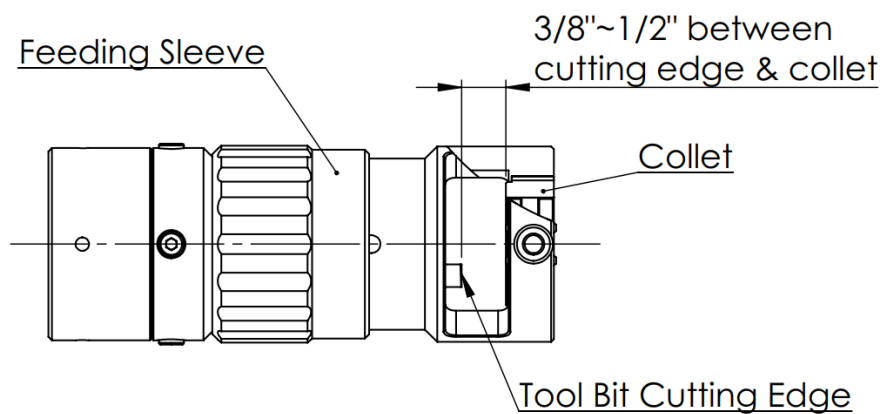

Tool Bit Initial Position

## TSM-1100 PORTABLE TUBE SQUARING MACHINE

- 5) Put tubing into collets and adjust tubing to leave 1/8" to 1/4" gap between cutting bit and tubing, and tighten down the Clamp Handle "Clockwise". See picture below

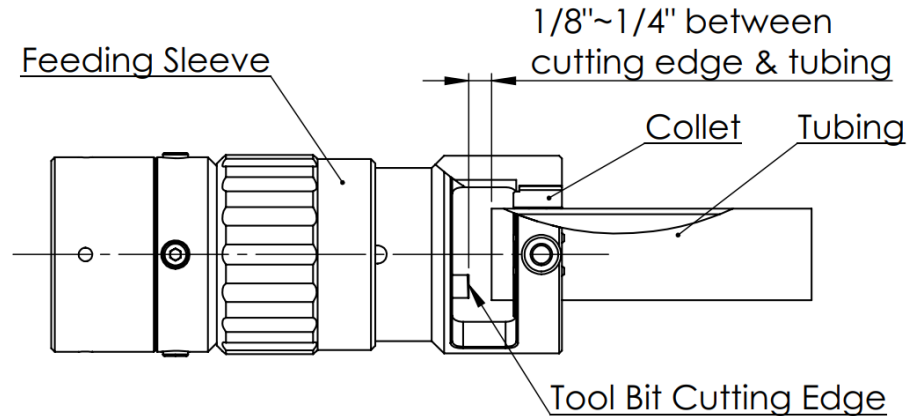

### Tubing Initial Position

- 6) Insert the battery back into the battery socket of the electric motor, and remember to have your safety glasses on.
- 7) Turn the motor in Clockwise direction and feed tubing by turning the Feeding Sleeve into the tubing. "**Remember**" you only want to have the motor turning at a lower speed without having the tool bit lock into the tubing or pipe when cutting stainless steel
- 8) When you have finish facing the tubing or pipe, un-screw the Clamp Handle and release the collet around the tubing. Remove tubing and repeat on next part.

The Elite Industrial Sales Tube Squaring Machine will last for many years with proper care and maintenance. Keep your equipment clean and repair for a long service life.

# **TSM-1100 PORTABLE TUBE SQUARING MACHINE**

## **6. MAINTENANCE**

### **GENERAL MACHINE MAINTENANCE**

During heavy operation, regularly use a brush to clean chips away from the machine. Wipe the machine down thoroughly when you are through with the machine. Do not spray anything into the electric motor body.

### **ELECTRIC MOTOR MAINTENANCE**

Periodically check the motor brushes for excess wear or damage. Replace as needed. Check the power cord for cuts, tears, or abrasions.

### **COLLET MAINTENANCE**

Keep clamp collets together in their respective sets. When not in use, store in case. Collet repair kits are available from your retailer.

### **TOOL BIT MAINTENANCE**

When possible, leave unused tool bits in their packages to prevent them from being damaged if dropped. Store tool bits that have been taken from their original package in a safe place.

# **TSM-1100 PORTABLE TUBE SQUARING MACHINE**

## **7. WARRANTY**

EVERY ELITE INDUSTRIAL SALES MACHINE/TOOL IS THOROUGHLY INSPECTED AND TESTED BEFORE LEAVING OUR MANUFACTURING FACILITIES. ALL PRODUCTS MANUFACTURED BY ELITE INDUSTRIAL SALES ARE WARRANTED TO THE ORIGINAL PURCHASER TO BE FREE FROM DEFECTS IN MATERIAL AND WORKMANSHIP UNDER NORMAL USE, FOR A PERIOD OF ONE YEAR FROM THE DATE OF PURCHASE. THIS DOES NOT INCLUDE TOOL BITS OR OTHER CONSUMABLE ITEMS. SHOULD ANY TROUBLES DEVELOP, RETURN THE COMPLETE TOOL PREPAID TO ELITE INDUSTRIAL SALES OR THE NEAREST AUTHORIZED SERVICE CENTER. IF INSPECTION SHOWS THE TROUBLE IS CAUSED BY DEFECTIVE WORKMANSHIP OR MATERIAL, ELITE INDUSTRIAL SALES AT ITS OPTION WILL REPAIR OR REPLACE WITHOUT CHARGE FOR EITHER PARTS OR LABOR. THE PRODUCT WILL BE RETURNED TO THE PURCHASER FREIGHT PREPAID AND BILLED TO THE PURCHASER.

### **THIS WARRANTY DOES NOT APPLY WHERE:**

- A) REPAIRS OR ATTEMPTED REPAIRS HAVE BEEN MADE BY PERSONS OTHER THEN ELITE INDUSTRIAL SALES PERSONAL, OR AUTHORIZED SERVICE REPAIR PERSONAL.
- B) REPAIRS ARE REQUIRED BECAUSE OF NORMAL WEAR.
- C) THE TOOL HAS BEEN ABUSED OR INVOLVED IN AN ACCIDENT.
- D) MISUSE IS EVIDENT, SUCH AS CAUSED BY OVERLOADING THE TOOL BEYOND IT RATED CAPACITY.

## **TSM-1100 PORTABLE TUBE SQUARING MACHINE**

- E) THE TOOL HAS BEEN USED AFTER PARTIAL FAILURE,  
OR THE TOOL HAS BEEN USED WITH AN IMPROPER  
ACCESSORY.

**NO OTHER WARRANTY EITHER WRITTEN OR  
VERBAL IS AUTHORIZED.**

# TSM-1100 PORTABLE TUBE SQUARING MACHINE

## 8. EXPLODED VIEWS AND PART #

### Standard Model:

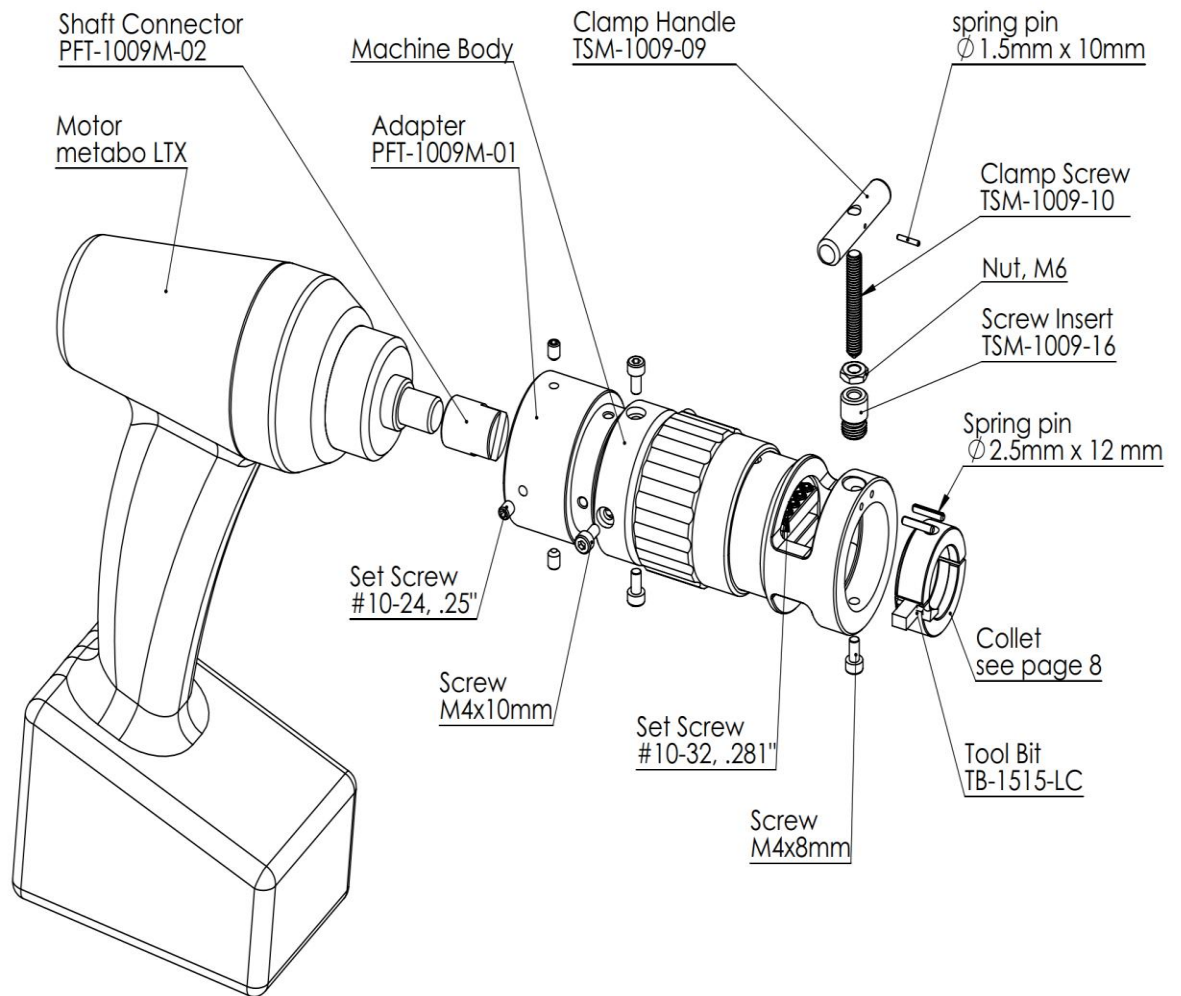

Exploded View, Standard Model

# TSM-1100 PORTABLE TUBE SQUARING MACHINE

## Machine with Optional Right Angle Drive:

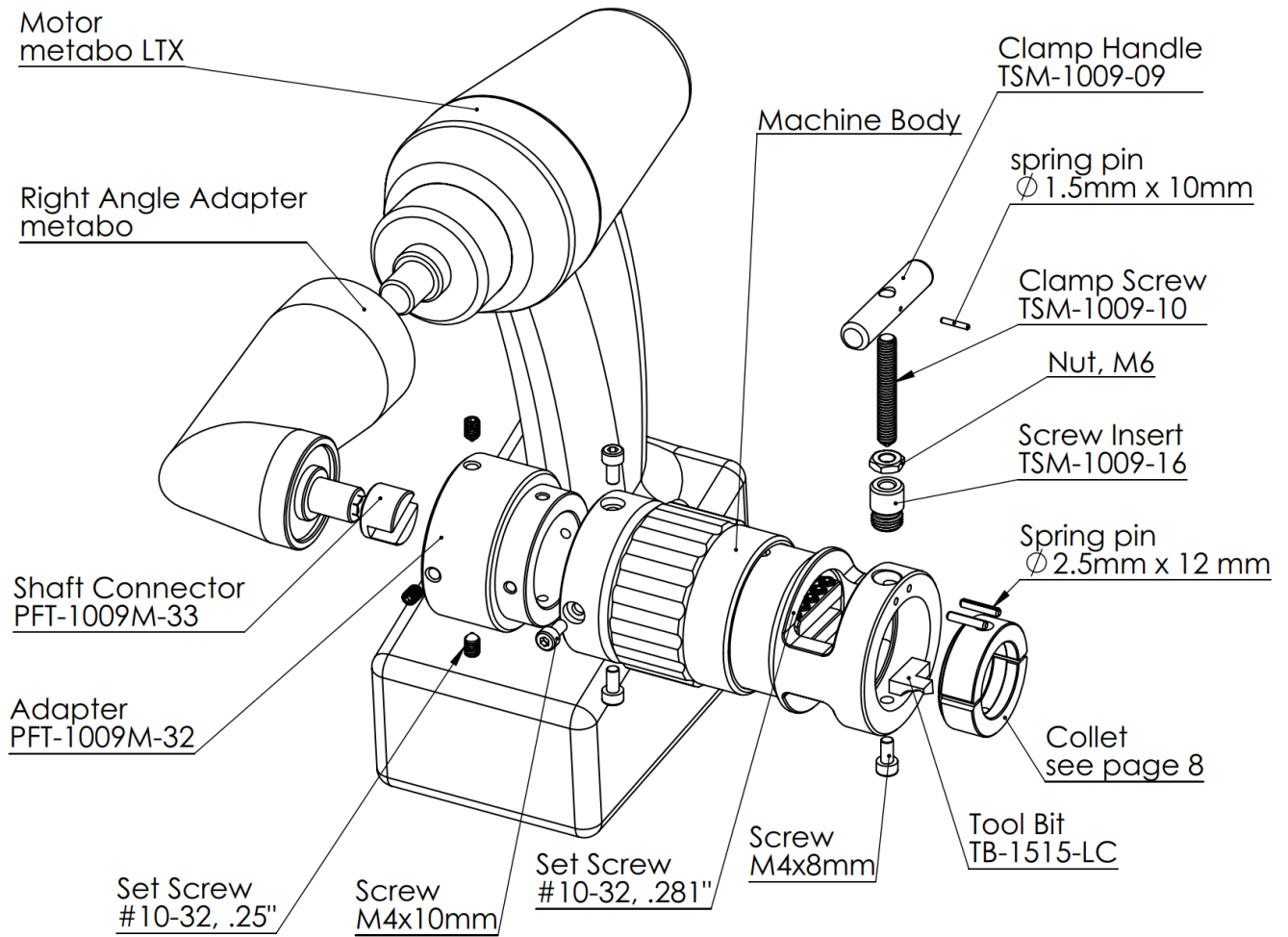

Exploded View, Machine with Optional Right Angle Drive